

## 2 YEAR LIMITED WARRANTY

For a period of two (2) years from date of purchase, **Shinn Fu Co. of America, Inc.** will repair or replace, at its option, without charge, any of its products which fails due to a defect in material or workmanship, or which fails to conform to any implied warranty not excluded hereby.

Performance of any obligation under this warranty may be obtained by returning the warranted product, freight prepaid, to **Shinn Fu Co. of America, Inc.** Warranty Service Department, 10939 N. Pomona Ave., Kansas City, MO 64153.

Except where such limitations and exclusions are specifically prohibited by applicable law, (1) the CONSUMER'S SOLE AND EXCLUSIVE REMEDY SHALL BE THE REPAIR OR REPLACEMENT OF DEFECTIVE PRODUCTS AS DESCRIBED ABOVE, and (2) **Shinn Fu Co. of America, Inc.** SHALL NOT BE LIABLE FOR ANY CONSEQUENTIAL OR INCIDENTAL DAMAGE OR LOSS WHATSOEVER, and (3) THE DURATION OF ANY AND ALL EXPRESSED AND IMPLIED WARRANTIES, INCLUDING WITHOUT LIMITATION, ANY WARRANTIES OF MERCHANTABILITY AND FITNESS FOR A PARTICULAR PURPOSE, IS LIMITED TO A PERIOD OF NINETY (90) DAYS FROM DATE OF PURCHASE.

Some states do not allow limitations on how long an implied warranty lasts, so the above limitation may not apply to you. Some states do not allow the exclusion or limitation of incidental or consequential damages, so the above limitation or exclusion may not apply to you. This warranty gives you specific legal rights, and you may also have other rights which vary from state to state.



## Heavy Duty Engine Crane

### Operating Instructions & Parts Manual

Model Number  
T-3202

Capacity  
2 Ton

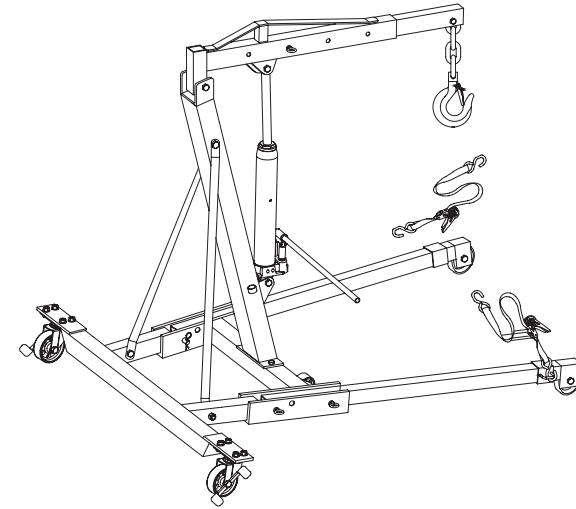

- ⚠ **WARNING:** Cancer and Reproductive Harm.
  - ⚠ **AVERTISSEMENT:** Cancer et dommages au système reproducteur.
  - ⚠ **ADVERTENCIA:** Cáncer y daño reproductivo.
- [www.P65Warnings.ca.gov](http://www.P65Warnings.ca.gov)

Shinn Fu Company of America, Inc.  
10939 N. Pomona Ave.  
Kansas City, MO 64153  
Phone (888)332-6419, fax (816)891-6599  
© Sept. 2018

Printed in China

**Save these instructions.** For your safety, read, understand, and follow the information provided with and on this engine crane. The owner and operator of this equipment shall have an understanding of this engine crane and safe operating procedures before attempting to use. The owner and operator shall be aware that use and repair of this product may require special skills and knowledge. Instructions and safety information shall be conveyed in the operator's native language before use of this engine crane is authorized. If any doubt exists as to the safe and proper use of this product, remove from service immediately. **Inspect before each use.** Do not use if broken, bent, cracked or damaged parts are noted. Any engine crane that appears damaged in any way, or operates abnormally shall be removed from service immediately. If the engine crane has been or suspected to have been subjected to a shock load (a load dropped suddenly, unexpectedly), immediately discontinue use until product has been checked by an authorized service center. It is recommended that an annual inspection be done by qualified personnel. Labels and Owners Manuals are available from manufacturer.

**PRODUCT DESCRIPTION**

This Pro-Lift Engine Crane is designed to safely lift and lower rated capacity engines. Welded steel tube construction, safety hook, steel castors ensure safety, strength and stability.

**BEFORE USE** (refer to Fig.1 and Replacement Parts Illustration on Page 6 for location of components)

1. Inspect crane before each use. Do not use if bent, broken or cracked components are noted. Ensure that casters and boom move freely. Check for and tighten any loose assemblies.
2. Verify that the product and the application are compatible, if in doubt call Pro-Lift Customer Support @ (888)332-6419.

**BEFORE USE** (continued)

3. Before using this product, read the owner's manual completely and familiarize yourself thoroughly with the product and the hazards associated with its improper use.

**⚠WARNING**

Read, understand and follow all warnings and instructional material provided on and with this product. This engine crane is intended to be used to lift and lower rated capacity automotive and light truck engines. Do not exceed rated capacity for each boom position. When removing and installing engines, ensure that crane's power unit is not jammed against vehicle. Use only on hard, level surfaces capable of supporting the load. Use only chains and slings with a capacity equal to or greater than that of the crane. If loaded crane must be moved, make certain that load is stable, is in lowest possible position and is moved over a smooth, hard level surface. Make sure that boom is fully lowered before checking or adding fluid to power unit. Avoid shock loads caused by the rapid opening and closing of release valve. Shock loads may cause the load to swing, causing the crane to flip violently, bend or break. Do not allow load to swing or drop violently while lowering or moving. Do not stand over loaded boom nor in its intended line of travel. Do not modify this equipment. Failure to heed this warning may result in personal injury as well as property damage.

**⚠ADVERTENCIA**

- Leer, comprender, y seguir las instrucciones antes de utilizar el aparato.
- El manual de instrucciones y la información de seguridad deben estar comunicado en lengua del operador antes del uso.
- No seguir estas indicaciones puede causar daños personales o materiales.

**SPECIFICATIONS**

Model	Boom Position	Capacity	Min. Hook Height	Max. Hook Height	Boom Length
T-3202	1	2 Ton	9"	74 7/8"	26 3/4"
	2	1 1/2 Ton	2 3/8"	81 1/8"	34 1/4"
	3	1 Ton	0"	87 3/8"	39 3/8"
	4	1/2 Ton	0"	93 1/4"	49 1/4"

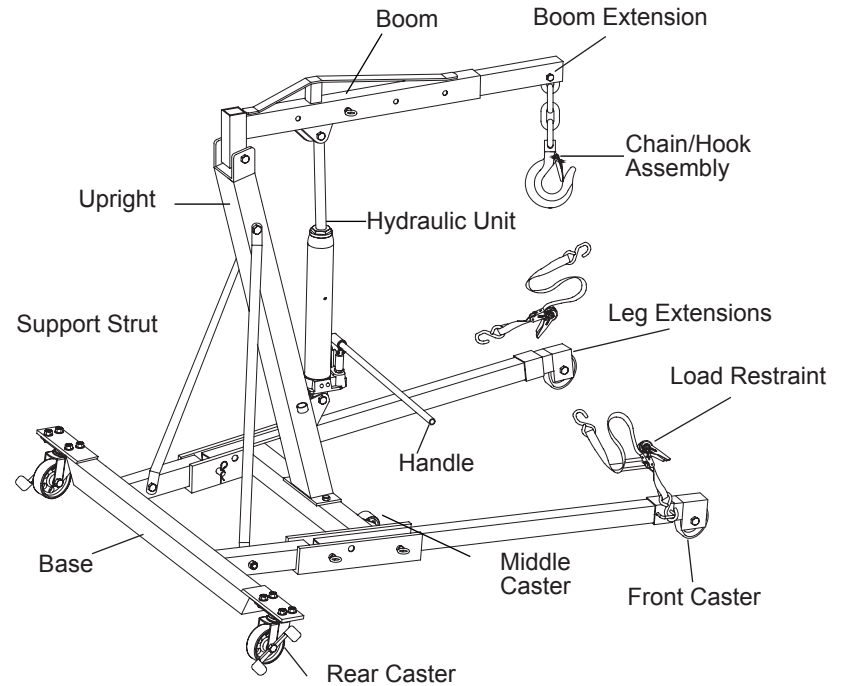

Fig. 1 - Engine Crane Nomenclature

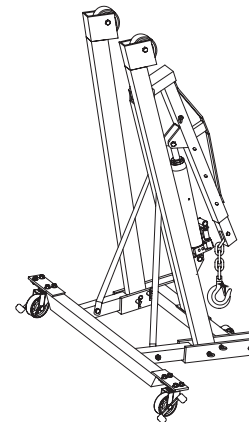

Fig. 2 - Engine Crane Storage Position

**Instruction on how to transform the crane into storage position: (see Fig. 2)**

1. Lower boom to its minimum height.
2. Remove forward most lock pin (Ref. No. 10 in figure 3) from each leg extension.
3. Carefully lift each leg into the upright position.
4. Reinstall lock pin (Ref. No. 10 in figure 3) into middle hole on base frame leg connection.

## ASSEMBLY

1. Attach (2) rear casters (ref. no 1) to base (ref. no 26) with M8 x 16 bolts (ref. no 2).
2. Attach (2) middle wheel (ref. no 11) and (2).
3. Slide on load restraint brackets (ref. no. 34) onto ends of legs (ref. no. 27).
4. Line up pivot hole on front leg (ref. no. 27) with corresponding rear pivot hole and secure with pin (ref. no. 10).
5. Attach upright (ref. no 29) to base (ref. no 26) with (2) M14 x 95 bolts (ref. no 8) and nuts (ref. no 7).
6. Attach (2) strut supports (ref. no. 30) to base (ref. no 26) and upright (ref. no. 29) with M14 x 95 bolts (ref. no.5), and M14 X 100 nuts (ref. no. 6).
7. Place hydraulic unit (ref. no. 25) on upright's support bracket and secure with M16 x 85 bolt (ref. no 5), and nut (ref. no. 6).
8. Attach boom (ref. no. 31) to upright (ref. no. 29) with M16 x 110 bolt (ref. no. 19), and nut (ref. no. 20).
9. Pump jack until ram is extended approximately 2".
10. Align the hole on the hydraulic ram with the mounting hole of boom and secure with the M16 x 85 lock bolt (ref. no. 5) and retainer nut (ref. no. 6).
11. Slide boom extension (ref. no. 32) into boom (ref. no. 31) and secure with the lock pin (ref. no. 21) and retainer lock pin (ref. no. 9).
12. Attach chain/hook assembly (ref. no. 33) to boom extension (ref. no.32) with M14 x 80 bolt (ref. no. 22), and nut (ref. no. 23).

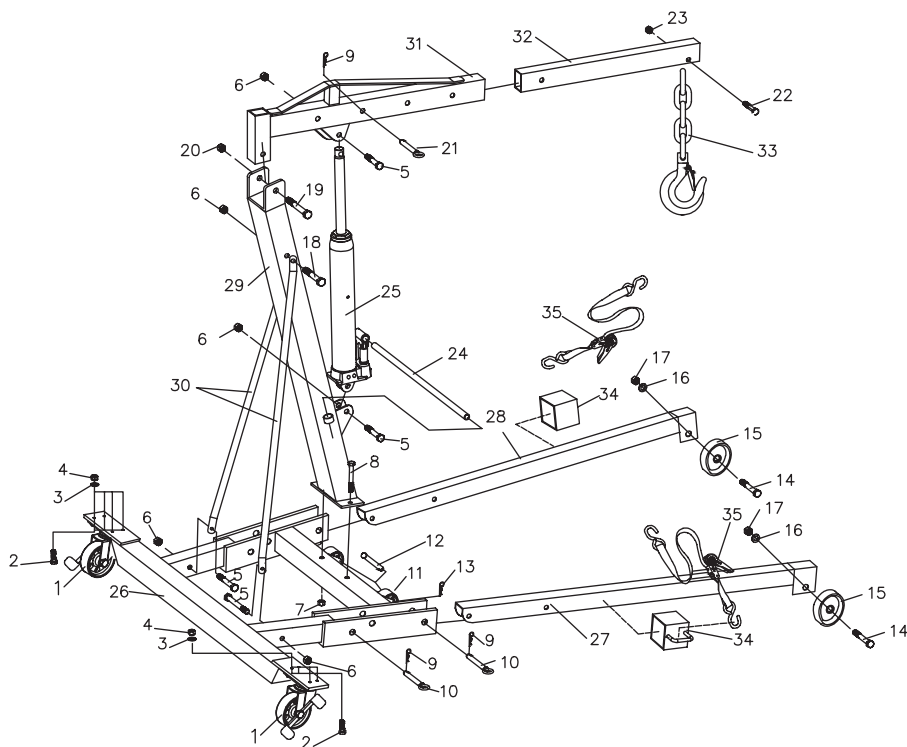

Fig. 3 - Assembly Illustration

## OPERATION

1. Ensure application is compatible with product.
2. Read, understand and follow engine removal and installation instructions provided by vehicle service or shop manual.
3. Chains used in conjunction with this product shall have a rated capacity greater than the weight of the object being lifted. Secure chain/hook assembly to appropriate lifting point on engine. Refer to vehicle service or shop manual for the location of appropriate lift points. Ensure load is centered.
4. When ready to remove engine, turn release valve clockwise until firm. Pump handle until load is securely supported by crane.
5. Remove engine, then immediately transfer the engine to appropriate engine support device (engine stand).
6. Check to ensure stand is secure before working on or around.

## ! WARNING

- Never extend leg extensions beyond factory marked position on each leg.
- Extend each leg extension an equal distance from frame.
- Never extend boom extension beyond furthest distance of leg extensions.
- Failure to heed these markings may result in personal injury and/or property damage.

## ! SAFETY MESSAGE !

Be sure all tools and personnel are clear before lowering load. No alterations shall be made to this device. Only attachments and/or adapters supplied by the manufacturer shall be used.

## MAINTENANCE

**Important:** Use only a good grade \*hydraulic jack oil. Avoid mixing different types of fluid and NEVER use brake fluid, turbine oil, transmission fluid, motor oil or glycerin. Improper fluid can cause failure of the jack and the potential for sudden and immediate loss of load.

## MAINTENANCE (continued)

### Adding oil

1. With jack fully lowered and handle sleeve fully depressed, carefully remove from crane. Set jack in an upright, level position. Remove oil filler plug.
2. Fill with hydraulic oil until just below the rim of the oil filler plug hole. Reinstall the oil filler plug.

### Changing oil

For best performance and longest life, replace the complete hydraulic oil supply at least once per year.

1. With jack fully lowered and handle sleeve fully depressed, remove jack from crane body. With jack in it's upright, level position, remove oil filler plug.
  2. Lay the jack on its side and drain the oil into a suitable container.
- Note:** Dispose of hydraulic oil in accordance with local regulations.
3. Set jack in it's upright, level position.
  4. Fill with hydraulic oil until just below the rim of the oil filler plug hole. Reinstall the oil filler plug.

### Lubrication

A periodic coating of light lubricating oil to pivot points, axles and hinges will help to prevent rust and assure that casters and pump assemblies move freely.

### Cleaning

Periodically check the pump piston and ram for signs of rust or corrosion. Clean as needed and wipe with an oily cloth.

**Note:** Never use sandpaper or abrasive material on these surfaces !

### Storage

Refer to Fig. 2 on page 3 for detail storage instruction.

## REPLACEMENT PARTS

Not all components of the jack are replacement items, but are illustrated as a convenient reference of location and position in the assembly sequence. When ordering parts, give model number, serial number and description below. Call or write for current pricing: phone (888)332-6419, fax (816)891-6599 or contact Pro-Lift Customer Support. 10939 N. Pomona Ave., Kansas City, MO 64153.

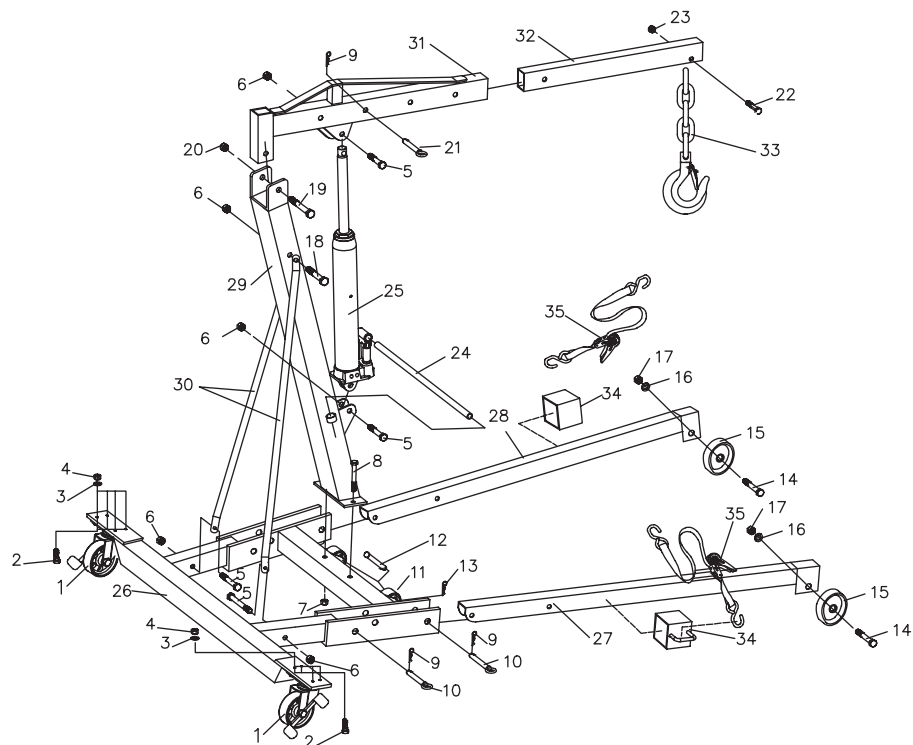

Item	Description	Qty
1	Caster 3.5"	2
2	Caster Bolt M8X25	8
3	Caster Lock Washer M8	8
4	Caster Nut M8	8
5	Bolt M 16X85	4
6	Nut M16	6
7	Nut M14	2

Item	Description	Qty
8	Bolt M14X110	2
9	Cotter Pin	5
10	Pin	4
11	Middle Wheel	2
12	Axle Pin	2
13	Cotter Pin	2
14	Axle Bolt M12X75	2
15	Front Wheel	2
16	Lock Washer M12	2
17	Nut M12	2
18	Bolt M16X100	1
19	Bolt M20X100	1
20	Nut M20	1
21	Pin	1
22	Bolt M14X75	1
23	Nut M14	1
24	Handle	1
25	Power Unit	1

## TROUBLESHOOTING

Symptom	Possible Causes	Corrective Action
Jack will not lift load	<ul style="list-style-type: none"> <li>Release valve not tightly closed</li> <li>Overload condition</li> </ul>	<ul style="list-style-type: none"> <li>Ensure release valve tightly closed</li> <li>Remedy overload condition</li> </ul>
Jack bleeds off after lift	<ul style="list-style-type: none"> <li>Release valve not tightly closed</li> <li>Overload condition</li> <li>Hydraulic unit malfunction</li> </ul>	<ul style="list-style-type: none"> <li>Ensure release valve tightly closed</li> <li>Remedy overload condition</li> <li>Contact Pro-Lift Customer Support</li> </ul>
Jack will not lower after unloading	<ul style="list-style-type: none"> <li>Reservoir overfilled</li> <li>Linkages binding</li> </ul>	<ul style="list-style-type: none"> <li>Drain fluid to proper level</li> <li>Clean and lubricate moving parts</li> </ul>
Poor lift performance	<ul style="list-style-type: none"> <li>Fluid level low</li> <li>Air trapped in system</li> </ul>	<ul style="list-style-type: none"> <li>Ensure proper fluid level</li> <li>With ram fully retracted, remove oil filler plug to let pressurized air escape, then reinstall oil filler plug</li> </ul>
Will not lift to full extension	<ul style="list-style-type: none"> <li>Fluid level low</li> </ul>	<ul style="list-style-type: none"> <li>Ensure proper fluid level</li> </ul>

\* "Bleeding off" means that jack begins to slowly lower rather than keep load at height.